

www.hzwmkj.com

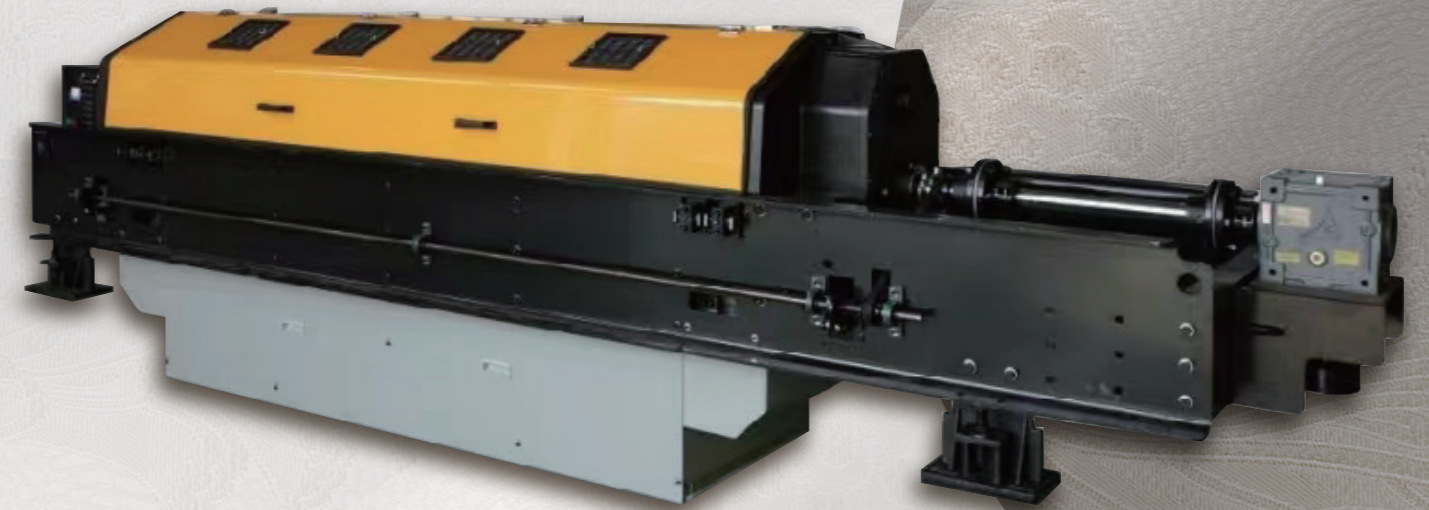

Creat the future of Jacquard.



浙江制造 品质生活
Zhejiang Makes It Happen



HANGZHOU WUMU TECHNOLOGY CO.,LTD.
Address 1: Room 723- B , Building 22, Weishang Mingfu , Wuchang Street ,
Yuhang District , Hangzhou City , Zhejiang Province , China
Address 2: No .600, Bujin Road , Qlixian Street , Keqiao District , Shaoxing
City , Zhejiang Province .
Tel :0086-571-851233650086-575-85398665
Sales Email :wumutech@163.com Service Email:wumuservice@163.com
Fax :0086-571-85125327 Zip Code :311121

HANGZHOU WUMU TECHNOLOGY CO.,LTD.



ENTERPRISE HONOR

- ◎ Reward of National Science and Technology Progress for twice
- ◎ Provincial Science and Technology Progress Award for six times
- ◎ Projects of the Ministry of Science and Technology Innovation Fund
- ◎ The National Torch Plan Item
- ◎ The National Torch Plan Item
- ◎ National Promotion Projects Achievement of Science and Technology
- ◎ National Award for Technology Progress
- ◎ Provincial Award for Technology Progress
- ◎ Electronic Jacquard Machine Industry Standard Drafting Unit.
- ◎ National High-Tech Enterprise
- ◎ National High-Tech Enterprise

The completely new factory of Hangzhou Wumu Technology Co., Ltd. landed in Keqiao as a major investment project covering with 37,000 square meters and put into production in 2020. The new plant effectively improves the production and quality.

COMPANY PROFILE

Hangzhou Wumu Technology Co., Ltd. is the oldest national high-tech enterprise specializing in electronic jacquard machine, a wide assortment of textile automation equipment and also textile Computer Aided Design (CAD) software research, development, production, sales and service.

Our researchers began to study textile automation in the 1970s. By the end of the 1980s, we had developed fabric systems competitive in markets worldwide. In the 1990s, we developed a series of products including in electronic jacquard machine, loom control systems, rug-overtufting machine control systems, fabric simulation CAD system etc. Our products won several national and provincial awards and also over 20 patents for Chinese inventions, practical and novel patents, software copyrights etc.

WUMU is on the drafting committee for national electronic jacquard industry standard. Products are used in the whole country and exported to India, Pakistan, Bangladesh, Vietnam, Indonesia, Japan, Uzbekistan, Kyrgyzstan, Jordan, Iran area and other countries and regions. Our main products include electronic jacquard machines as WMT, WMZ-L, WMF, WMF-Z series, woven samples, double shed electronic jacquard machine, loom control system, rug-overtufting machine control system, fabric CAD software, fabric simulation CAD etc. Fabric software is loved by masses of users and this top sale product has the widest influence in the domestic market.

With the target "integrity, technology, quality and service", WUMU will ensure better products and service for domestic and overseas customers.



ELECTRONIC JACQUARD MACHINE

- WMT SERIES
- WMZ-L SERIES
- WMF SERIES
- WMF-Z SERIES



I、PRODUCT INTRODUCTION

Electronic jacquard machine combines modern microelectronic technology with electromagnetic and photoelectric technology. It has realized a high-speed jacquard with the cooperation of the fabric CAD system and a new type of mechanical construction.

II、TYPE

Electronic jacquard machine has four series and nearly 50 different species. Needles range is from tens to over one thousand.

Module Type

WMT: WMT1408, WMT2816, WMT3072, WMT3072-24, WMT5120, WMT5376, WMT5376-24, WMT6144, WMT6912, WMT8448, WMT10240, WMT12288, WMT13312, WMT14336.

WMF-Z: WMF1536Z, WMF2816Z, WMF5376Z, WMF6144Z.

WMZ-L: WMZ1024L, WMZ1408L, WMZ1792L, WMZ2816L.

Sheet Steel Type

WMF: WMF1344B, WMF1792B, WMF2688B, WMF3584B, WMF4608B, WMF6144B, WMF6528B, WMF7680B.

III、RANGE OF APPLICATION

Looms with shuttle and shuttleless. It is suitable for tie, silk, towel and a variety of fabrics.



IV、PRODUCT ADVANTAGES

With all these national patents and its elaborate design, electronic jacquard machines can meet demands of the weaving industry in domestic market and overseas.

V、CONSTRUCTION FEATURES

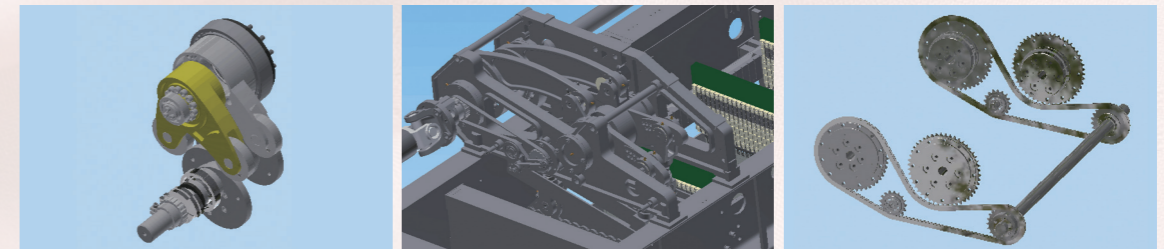

CONJUGATE CAM

ECCENTRIC DRIVING

CHAINWHEEL

- ⊙ Improve the speed.
- ⊙ Precisely balanced double motion type lifts.
- ⊙ A simple way to adjust knife height and shed size system.
- ⊙ Strong lifting gear.
- ⊙ Multi-position adjustable CAM selvage mechanisms.

VI、CUSTOMERS DELEGATIONS





CHARACTERISTICS

It is a brand-new high-quality electronic jacquard machine especially developed for heavy-duty craft and high-speed loom. The mechanical transmission system has been optimized and improved. It can reduce the waste of warp in shedding by adopting cam structure transmission method. The mechanical transmission is stable and the noise is low. At the same time, the energy consumption for the heavy-duty jacquard process will be greatly reduced by adopting low-power consumption module needle selection method. It adopts embedded intelligent control module and touch screen human-computer interaction interface, which has a better control experience and can meet the requirements of long-term high-speed operation. It can use shaftless synchronous transmission with loom by its own power source.

RANGE OF APPLICATION

It is mainly used in various imported and domestic high-speed rapier looms, air-jet loom, water-jet loom and projectile loom. It is used to produce all kinds of textiles such as trademarks, ties, clothing fabrics, decorative fabrics, scarves and tapestry etc. Especially for the heavy-duty lifting craft, the advantages of this jacquard machine are very prominent.



ELECTRONIC JACQUARD OF WMT-A SERIES

PRODUCT INTRODUCTION

- ◎ **Type:** WMT2816A, WMT5376A, WMT6144A, WMT6912A, WMT8448A, WMT12288A
- ◎ **Max Speed:** Upto 650 RPM
- ◎ **Selection Method:** Module + drive plate + aluminum alloy handle
- ◎ **Shedding Form:** Conjugate CAM structure, positive double-lift, fully-open shedding mechanism
- ◎ **Shedding Height:** The front shedding height range is 45-109mm, back shedding height range is 72-120mm with easy adjustment.
- ◎ **Transmission Mode:** Vertical shaft + gearbox or None-vertical shaft
- ◎ **Note:** Other specifications can be customized according to customers' requirements



OUTLOOK

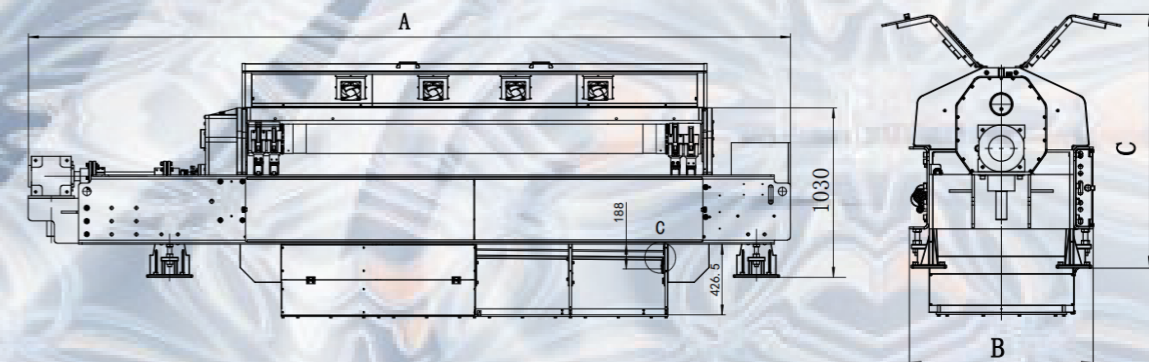

TECHNOLOGY PARAMETER

Type	Length A (mm)	Width B (mm)	Height C (mm)	Weight (kg)
WMT2816A	4030	940	1030(1340)	2100
WMT5376A	4454	940	1030(1340)	2500
WMT6144A	4624	940	1030(1340)	3000
WMT6912A	4034	1260	1100	3500
WMT8448A	4325	1260	1100	4000
WMT12288A	4670	1532	1154	4500

PRODUCT





CHARACTERISTICS

This high quality electronic jacquard machine is designed specially for heavy duty designs or high speed looms. Driving system is optimized and improved which makes the machine running in stable and low noise to make good use of shedding height. Power consumption will decrease when it runs in heavy duty designs by using module selection. Embedded intelligent control module and touch-screen human-computer interaction interface has better experience. It can meet the requirement of running in high-speed and long term. Customized servo or motor runs in no vertical shaft but synchrodrive with looms.

RANGE OF APPLICATION

Matching with all kinds of overseas and domestic high speed rapier looms, air jet looms, water jet looms and projectile looms. It is suitable for trademark, tie, garment fabric, decorative fabric, shawl, towel, tapestry etc. This electronic jacquard advantage is very outstanding especially for heavy duty designs.



ELECTRONIC JACQUARD OF WMT SERIES

PRODUCT INTRODUCTION

- ◎ **Type:** WMT1408, WMT2816, WMT3072, WMT3072-24, WMT5120, WMT5376, WMT5376-24, WMT6144, WMT6912, WMT8448, WMT10240, WMT12288, WMT13312, WMT14336
- ◎ **Speed:** Upto 650RPM
- ◎ **Selection Method:** module+ drive circuit board + aluminum alloy lifting knife
- ◎ **Shedding Form:** conjugate CAM, positive double-lift, fully-open shedding mechanism
- ◎ **Shedding Height:** The front shedding width range is 45-109mm. Back shedding width range is 72-120mm with easy adjustment.

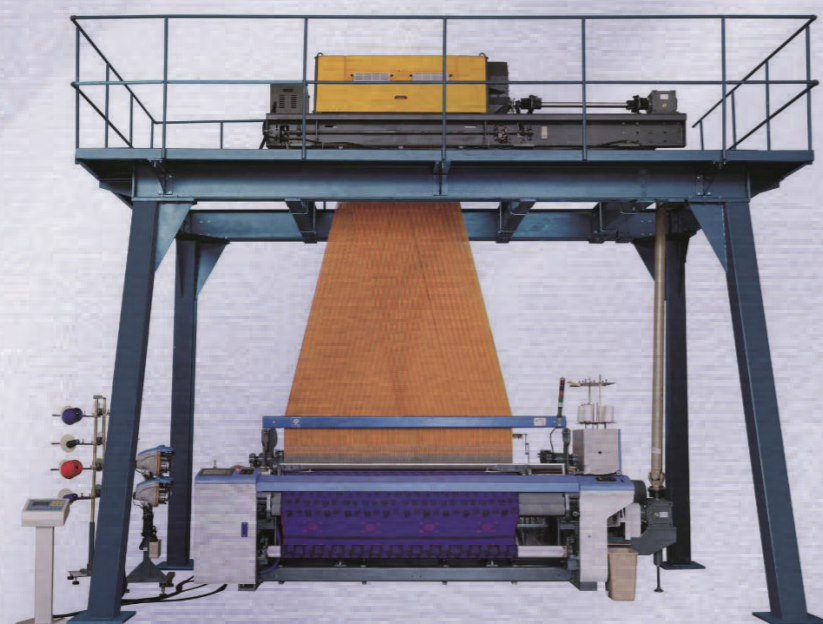

OUTLOOK

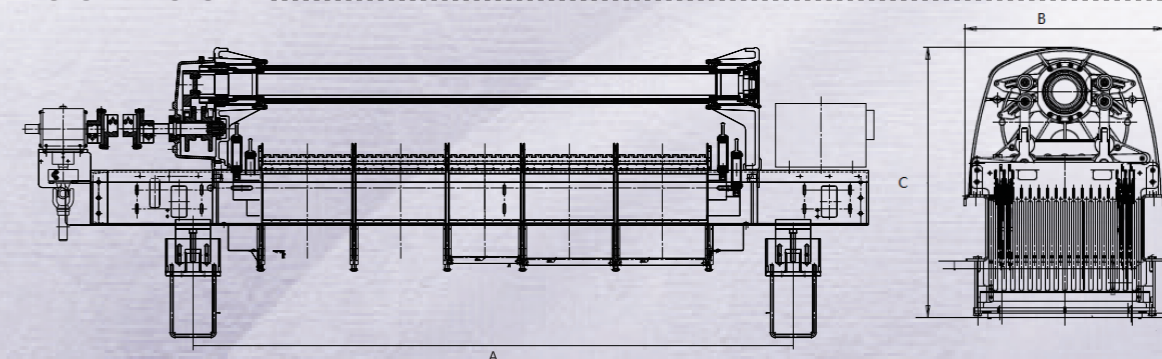

TECHNOLOGY PARAMETER

Type	Length A (mm)	Width B (mm)	Height C (mm)	Weight (kg)
WMT1408	1700	948	1170	1000
WMT2816	1950	948	1170	1450
WMT3072	1980	948	1170	1550
WMT3072-24	1890	1320	1250	1600
WMT5120	2800	948	1170	1950
WMT5376	2910	946	1030	2200
WMT5376-24	2500	1320	1250	2250
WMT6144	3260	948	1170	2150
WMT6912	2900	1320	1250	2200
WMT8448	3260	1320	1250	2500
WMT10240	2940	1700	1250	3000
WMT12288	3340	1700	1250	3500
WMT13312	3540	1700	1250	3600
WMT14336	3800	1700	1250	3700



CHARACTERISTICS

This model adopts double-sided four-eccentric wheel mechanical transmission mode, which runs smoothly with low mechanical vibration and low noise;

Double-sided wall plate are made of castings with small deformation and reduce the load of the machine itself;

The height of the knife opening is designed with positive and negative threads, and the adjustment method is simple;

Adopt high-performance modules + aluminum alloy knife selection method, good reliability, long life and reduce energy consumption;

The frame adopts steel plate laser cutting, overall bending and finishing to ensure the reliable operation of the needle selection system in the high-speed operation environment.

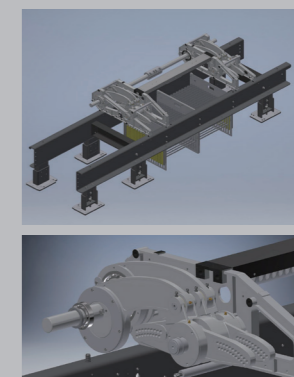

RANGE OF APPLICATION

Matching with all kinds of trademark machines, water jet loom and rapier looms. It is suitable for tie, silk, towel and a variety of fabrics.

ELECTRONIC JACQUARD OF WMF-Z SERIES

PRODUCT INTRODUCTION

- ◎ **Type:** WMF1536Z、WMF2816Z、WMF5376Z、WMF6144Z
- ◎ **Max Speed:** 450 RPM
- ◎ **Selection Method:** module + drive circuit board + aluminum alloy lifting knife
- ◎ **Shedding Form:** double-lift, fully-open shedding
- ◎ **Shedding Height:** The front shedding width range is 45-105mm. Back shedding width range is 62-120mm with easy adjustment.
- ◎ **Note:** Other specification can be made according to customers requirements



OUTLOOK

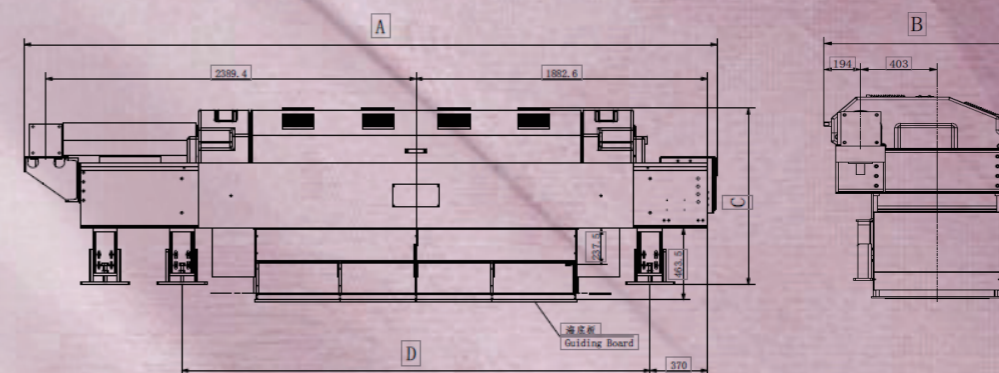

TECHNOLOGY PARAMETER

Type	Length A (mm)	Width B (mm)	Height C (mm)	Weight (kg)
WMF1536Z	2758	1084	928	1600
WMF2816Z	3770	1055	1140	1800
WMF5376Z	4475	1055	1140	2600
WMF6144Z	4774	1084	983	2800



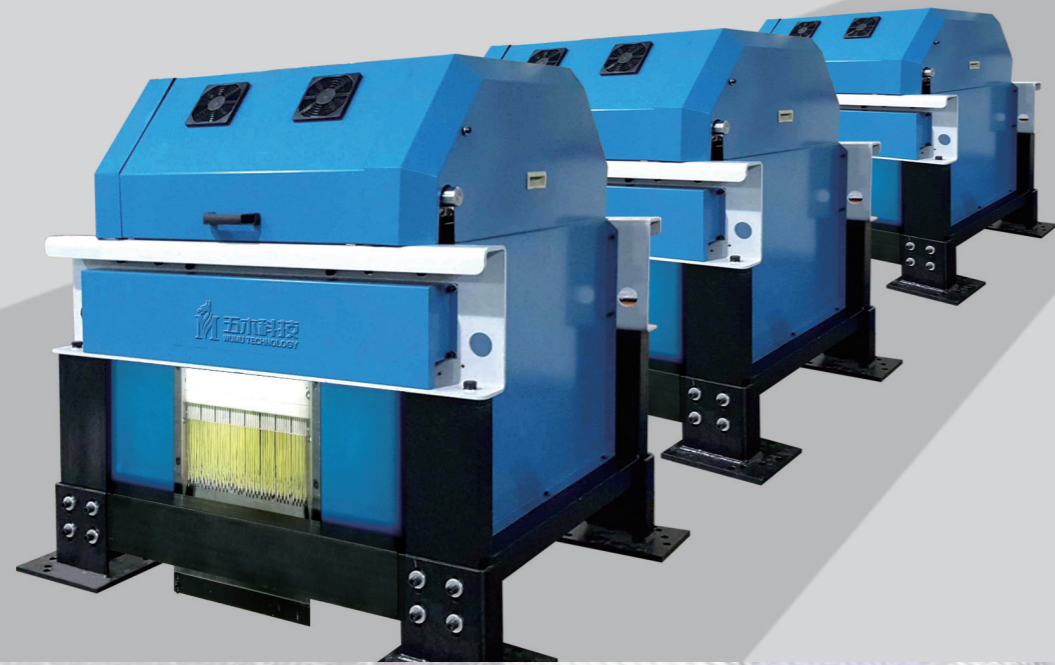

CHARACTERISTICS

This series of high cost-effective electronic jacquard machine is designed specially for shuttle loom and medium and low speed rapier looms. The mechanism uses chain wheel which is very stable and in lower noise. We can supply customized independent servo or motor driving mode. By using module which is in lower energy consumption, Electric part gets better anti-electromagnetic interference capability and circuit protection.

RANGE OF APPLICATION

Matching with shuttle loom and medium and low speed rapier looms. Suitable for weaving label, saree, towel, shawl etc.

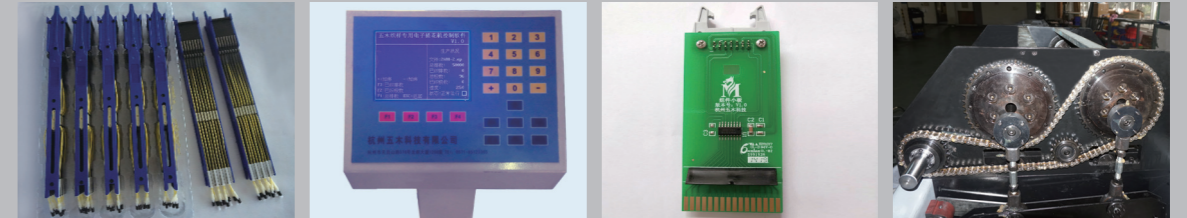

ELECTRONIC JACQUARD OF WMZ-L SERIES

PRODUCT INTRODUCTION

- ◎ **Type:** WMZ1024L, WMZ1408L, WMZ1792L, WMZ2816L
- ◎ **Speed:** Upto 250RPM
- ◎ **Selection Method:** module+ drive circuit board +aluminum alloy lifting knife
- ◎ **Shedding Form:** double-lift, fully-open shedding
- ◎ **Shedding Height:** The front shedding width range is 55-97mm. Back shedding width range is 97-120mm with easy adjustment.
- ◎ **Driving Mode:** Vertical shaft + gear box / Customized Servo or Motor
- ◎ **Note:** Other specification can be made according to customers' requirements.

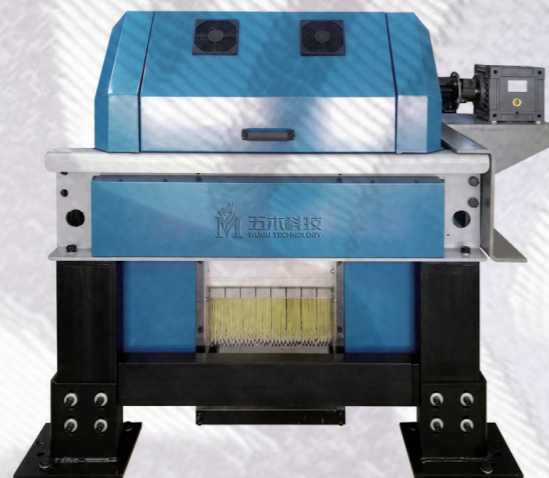

OUTLOOK

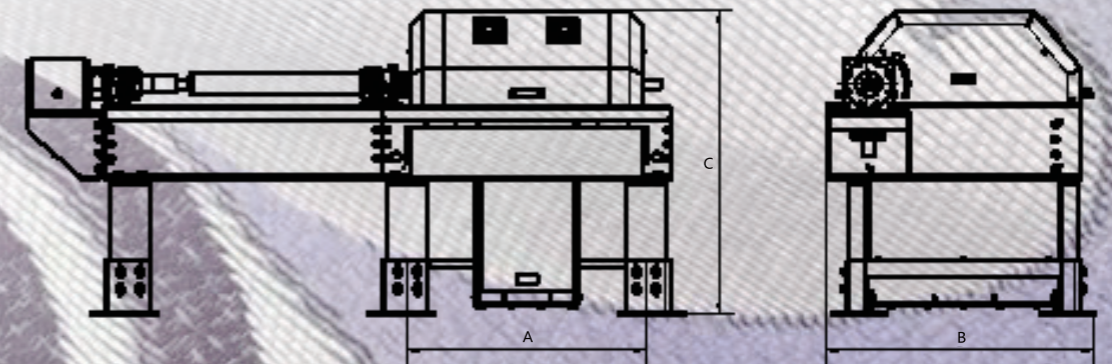

TECHNOLOGY PARAMETER

Type	Length A (mm)	Width B (mm)	Height C (mm)	Weight (kg)
WMZ1024L	745	1029	892	298
WMZ1408L	902	1029	892	310
WMZ1792L	1076	1029	997	575
WMZ2816L	1444	1029	892	632

PRODUCT



FABRIC CAD SOFTWARE

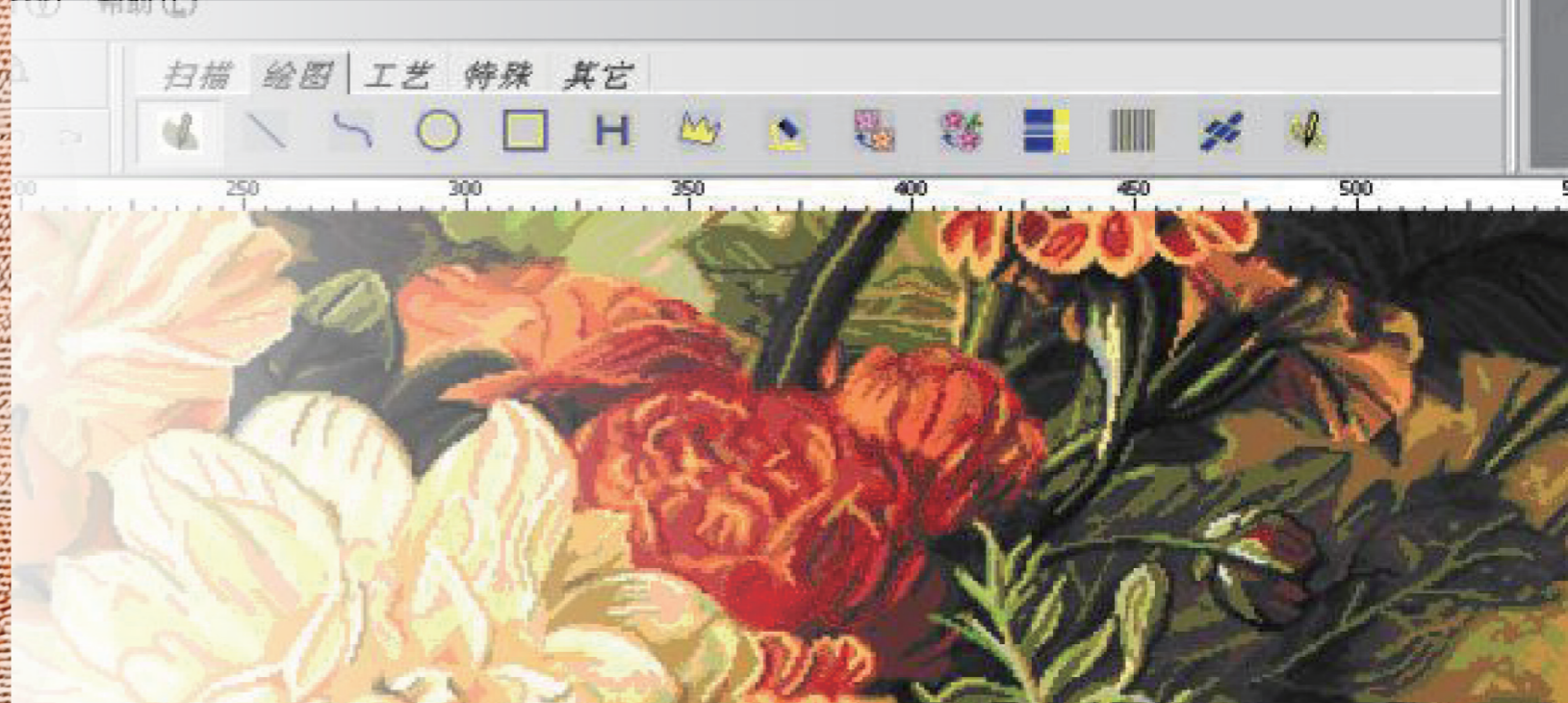

JACQUARD FABRIC CAD

PRODUCT SPECIFICATION

It has powerful graphic design and perfect textile process. The technology has reached the world advanced level. Jacquard CAD software is suitable for lable, silk, towel carpet, tie, furnishing cloth etc.

MAIN FUNCTIONS

- ⊙ The technique for scanning and connection and also slant correction.
- ⊙ Draw all kinds of geometric figures.
- ⊙ Copy. It can rotate any angles and change warp and weft.
- ⊙ Efficient editor can add and delete any warp and weft.
- ⊙ Hardware magnifications. Zoom lens and inspect everywhere.
- ⊙ Selvage selvage for inside, outside, up, down, left and right weaving.
- ⊙ Automatic and manual control of the length of yarns.
- ⊙ Restore the part infinitely.
- ⊙ Weave single layer fabric and double layers of fabric and also complex designs.
- ⊙ The standard organization database is available for customers any time.
- ⊙ Accurate analysis of weaving with ep /jc5 etc.
- ⊙ Strongest design and message-processing function.
- ⊙ Free setting the starting point.

NATIONAL PATENTS



FABRIC SIMULATION CAD

PRODUCT SPECIFICATION

Jacquard Fabric Simulation System is the virtual reality using computer graphic technology. Very vivid effects can enhance the competition for development and creativity for textile enterprise. The simulation design is used for silk, tower, tie, fabric weaving etc.

MAIN FUNCTIONS

- ⊙ Professional yarn design functions.
- ⊙ Stimulate different kinds of yarns like nubby yarn etc.
- ⊙ Practical yarn selection to set different quantity and thickness for warp and weft.
- ⊙ Simulation according to general circulation models or weft density parameter.
- ⊙ Show the vivid weaving of expression on the computer.

NATIONAL PATENTS

